

N3PT028MP120K

1200 V 28 mΩ Silicon Carbide MOSFET

V_{DS}	I_D	$R_{DS(on)}$	Package
1200 V	72 A	28 mΩ	TO-247-4

Features

- State-of-the-art SiC MOSFET technology
- Reliable gate oxide process
- 100% avalanche tested
- Low input capacitance
- Best-in-class figure-of-merits, $[R_{on} * C_{iss}]$ and $[R_{on} * C_{rss}]$
- Stable switching characteristics up to 175 °C

Benefits

- Higher system efficiency
- Reduced cooling requirements
- Increased power density
- Increased system switching frequency
- Enhanced system reliability
- Reduced total harmonic distortion

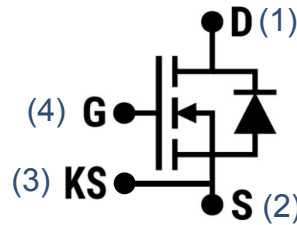

(1) (2) (3) (4)

Applications

- Motor drives
- Solar PV inverters
- EV onboard chargers
- Server power supplies
- Energy storage systems
- EV fast charging stations
- Solid-state power controllers
- Uninterruptible power supplies

Maximum Ratings

Parameter	Symbol	Test Conditions	Min.	Typ.	Max.	Unit	Note
Drain-Source Voltage	$V_{(BR)DSS}$	$T_C = 25\text{ °C}$	1200	-	-	V	
Gate-Source Voltage	$V_{GS(max)}$		-10	-	25	V	
	$V_{GS,op}$	Recommended Operation	-	-5/+20	-		
Continuous Drain Current	I_D	$V_{GS} = 20\text{ V}, T_C = 25\text{ °C}$	-	-	72	A	Fig. 13
		$V_{GS} = 20\text{ V}, T_C = 100\text{ °C}$	-	-	51		
Pulsed Drain Current	$I_{D(pulse)}$	$T_C = 25\text{ °C}$	-	-	160	A	Fig. 12
Power Dissipation	P_{tot}	$T_C = 25\text{ °C}$	-	-	268	W	Fig. 14
Avalanche Energy, Single Pulse	E_{AS}	$L = 26\text{ mH}, I_{AS} = 5.5\text{ A}$	-	390		mJ	
Operating and Storage Temperature	T_J, T_{stg}		-55	-	175	°C	

Thermal and Package Characteristics

Parameter	Symbol	Test Conditions	Min.	Typ.	Max.	Unit	Note
Thermal Resistance, Junction to Case	R_{thJC}		-	0.41	0.56	°C/W	Fig. 11
Thermal Resistance, Junction to Ambient	R_{thJA}		-	-	40	°C/W	
Weight	W_T		-	6.34	-	g	
Solder Temperature	T_L	JEDEC J-STD-020	-	-	225	°C	
Mounting Torque	T_M	M3 or 6-32 screw	-	0.9	-	Nm	

Electrical Characteristics ($T_c = 25\text{ °C}$ unless otherwise specified)

STATIC CHARACTERISTICS

Parameter	Symbol	Test Conditions	Min.	Typ.	Max.	Unit	Note
Drain-Source Breakdown Voltage	$V_{(BR)DSS}$	$V_{GS} = 0\text{ V}, I_D = 100\text{ }\mu\text{A}$	1200	-	-	V	
Zero Gate Voltage Drain Current	I_{DSS}	$V_{DS} = 1200\text{ V}, V_{GS} = 0\text{ V}$	-	1	100	μA	
Gate Threshold Voltage	$V_{GS(th)}$	$V_{GS} = V_{DS}, I_D = 25\text{ mA}$	1.8	2.4	3	V	
Gate-Source Leakage Current	I_{GSS}	$V_{GS} = -10 / +25\text{ V}, V_{DS} = 0\text{ V}$	-	-	± 100	nA	
Transconductance	g_{fs}	$V_{DS} = 10\text{ V}, I_D = 40\text{ A}$	-	20.2	-	S	Fig. 8
Drain-Source On-State Resistance	$R_{DS(on)}$	$V_{GS} = 20\text{ V}, I_D = 40\text{ A}$	-	25	35	mΩ	Fig. 1
		$V_{GS} = 20\text{ V}, I_D = 40\text{ A}, T_c = 175\text{ °C}$	-	51	-	mΩ	Fig. 3
		$V_{GS} = 18\text{ V}, I_D = 40\text{ A}$	-	27	-	mΩ	Fig. 1
		$V_{GS} = 18\text{ V}, I_D = 40\text{ A}, T_c = 175\text{ °C}$	-	52	-	mΩ	Fig. 3

DYNAMIC CHARACTERISTICS

Parameter	Symbol	Test Conditions	Min.	Typ.	Max.	Unit	Note
Input Capacitance	C_{iss}	$V_{GS} = 0\text{ V}, V_{DS} = 800\text{ V}, V_{AC} = 25\text{ mV}, f = 100\text{ kHz}$	-	2250	-	pF	Fig. 10
Output Capacitance	C_{oss}		-	116	-		
Reverse Capacitance	C_{rss}		-	6.5	-		
Gate-Source Charge	Q_{GS}	$V_{DS} = 800\text{ V}, V_{GS} = -5 / +20\text{ V}, I_D = 40\text{ A}$	-	16	-	nC	Fig. 15
Gate-Drain Charge	Q_{GD}		-	20	-		
Total Gate Charge	Q_G		-	106	-		
Internal Gate Resistance	$R_{G(int)}$	$V_{AC} = 25\text{ mV}, f = 1\text{ MHz}$	-	1.3	-	Ω	
Turn-On Switching Energy	E_{ON}	$V_{DD} = 800\text{ V}, I_D = 40\text{ A}, V_{GS} = -5 / +20\text{ V}, R_{G(ext)} = 5\text{ Ω}, L = 500\text{ μH}$	-	389	-	μJ	Fig. 16 Fig. 17 Fig. 18
Turn-Off Switching Energy	E_{OFF}		-	81	-		
Total Switching Energy	E_{TOT}		-	470	-		
Turn-On Delay Time	$t_{d(on)}$	$V_{DD} = 800\text{ V}, I_D = 40\text{ A}, V_{GS} = -5 / +20\text{ V}, R_{G(ext)} = 5\text{ Ω}, L = 500\text{ μH}$ Timing relative to V_{DS} Inductive Load	-	13	-	ns	Fig. 19
Rise Time	t_r		-	15	-		
Turn-Off Delay Time	$t_{d(off)}$		-	40	-		
Fall Time	t_f		-	10	-		

BODY DIODE CHARACTERISTICS

Parameter	Symbol	Test Conditions	Min.	Typ.	Max.	Unit	Note
Diode Forward Voltage	V_{SD}	$V_{GS} = -5\text{ V}, I_{SD} = 40\text{ A}$	-	4.8	-	V	Fig. 20
		$V_{GS} = -5\text{ V}, I_{SD} = 40\text{ A}, T_J = 175\text{ °C}$	-	4.4	-	V	Fig. 21
Continuous Diode Forward Current	I_S	$V_{GS} = -5\text{ V}$	-	-	51	A	
Reverse Recovery Time	t_{rr}	$V_R = 800\text{ V}, I_{SD} = 40\text{ A}, V_{GS} = -5\text{ V}, di_F/dt = 1000\text{ A/μs}$	-	22	-	ns	
Reverse Recovery Charge	Q_{rr}		-	117	-	nC	
Peak Reverse Recovery Current	I_{RRM}		-	14	-	A	

Typical Performance

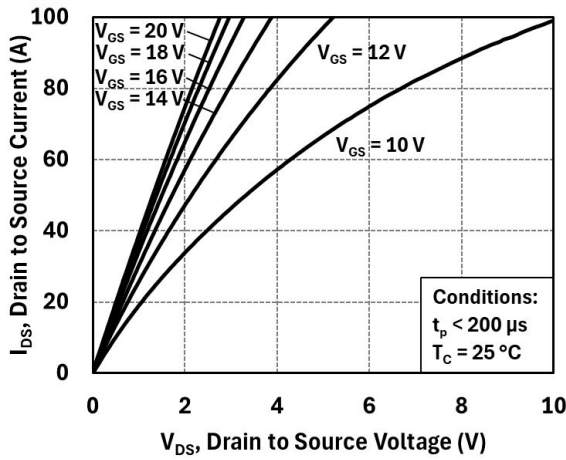

Figure 1: Output Characteristics at 25 °C

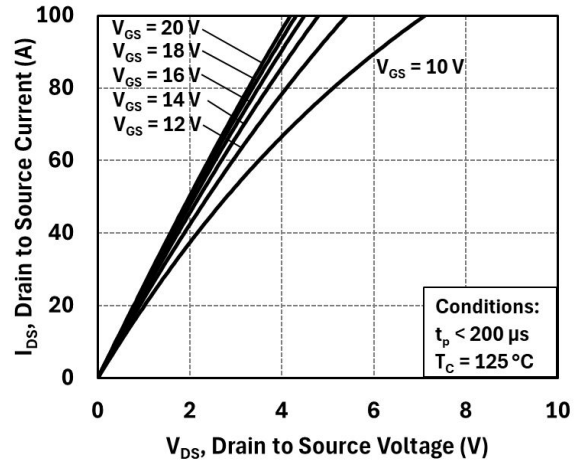

Figure 2: Output Characteristics at 125 °C

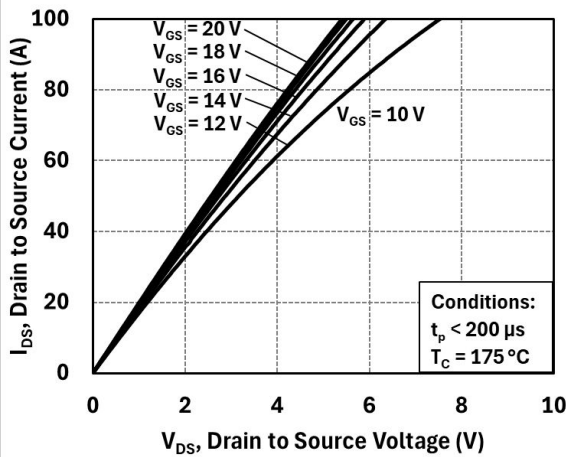

Figure 3: Output Characteristics at 175 °C

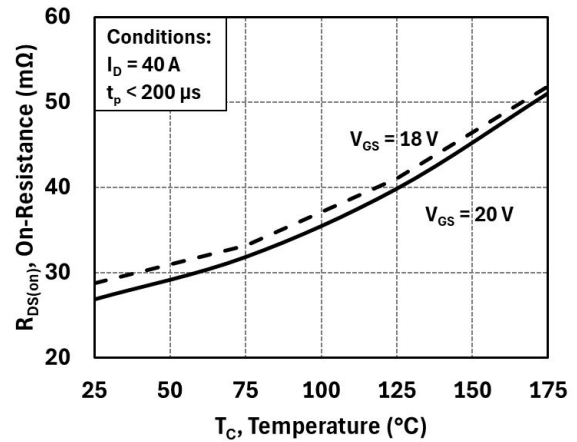

Figure 4: On-Resistance vs. Temperature

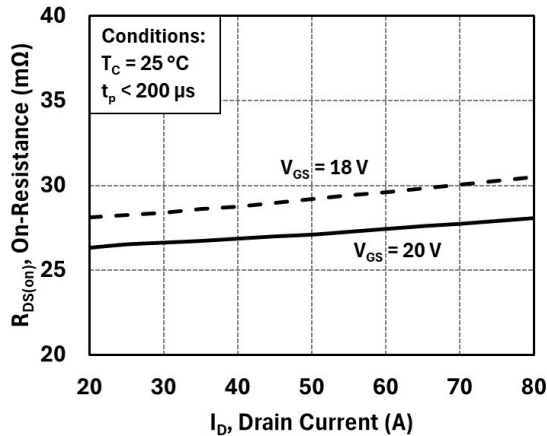

Figure 5: On-Resistance vs. Drain Current

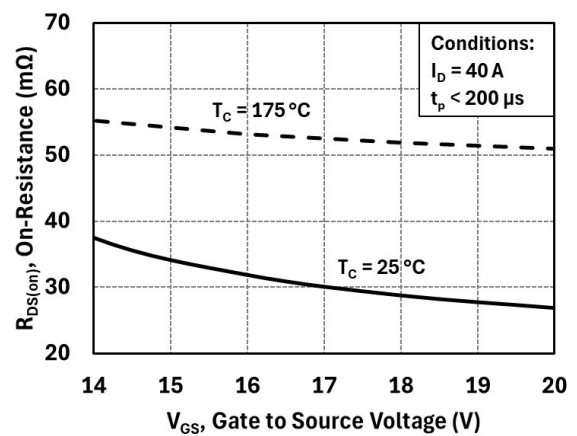

Figure 6: On-Resistance vs. Gate Voltage

Typical Performance

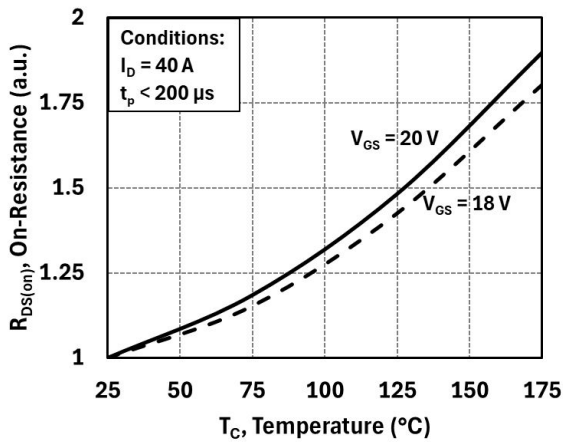

Figure 7: Normalized On-Resistance vs. Temperature

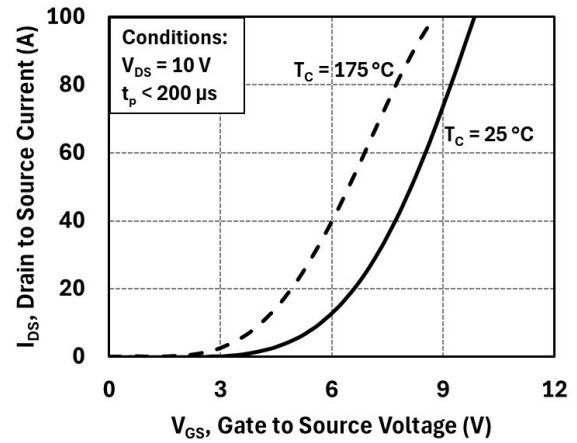

Figure 8: Transfer Characteristics

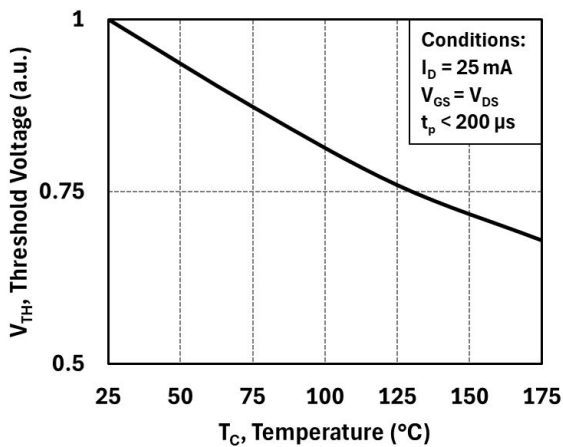

Figure 9: Threshold Voltage vs. Temperature

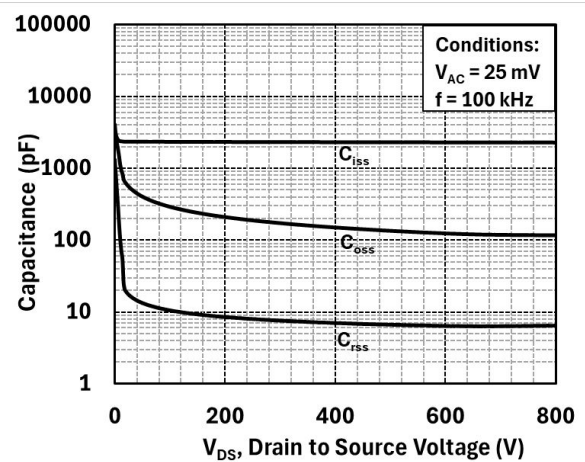

Figure 10: Capacitances vs. Drain-Source Voltage (0-1000 V)

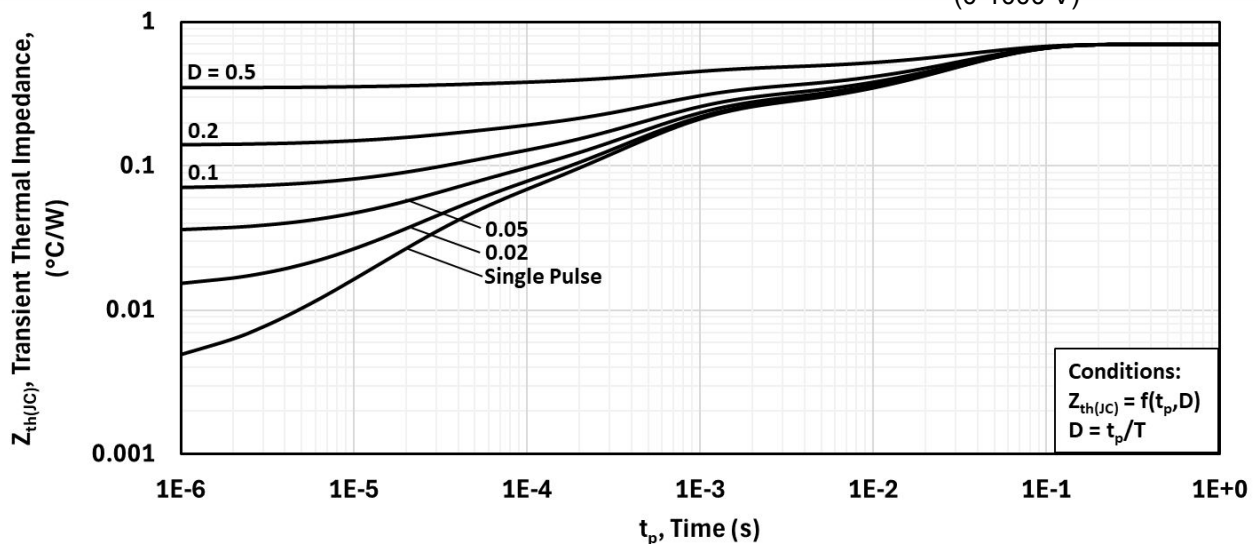

Figure 11: Transient Thermal Impedance

Typical Performance

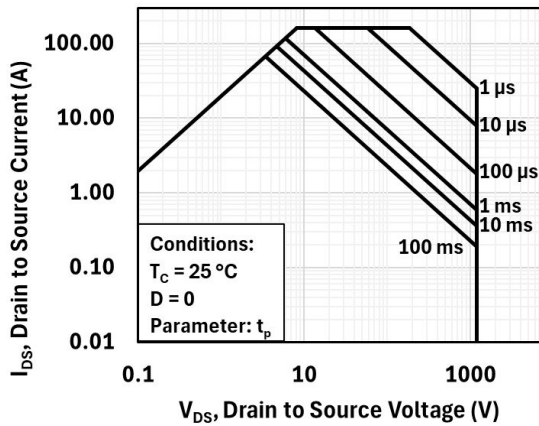

Figure 12: Safe Operating Area

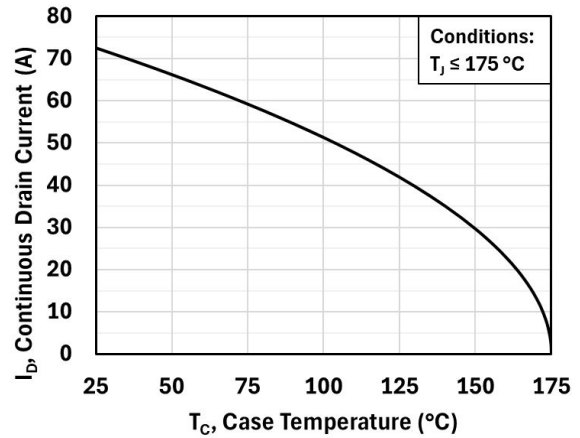

Figure 13: Current De-rating Curve

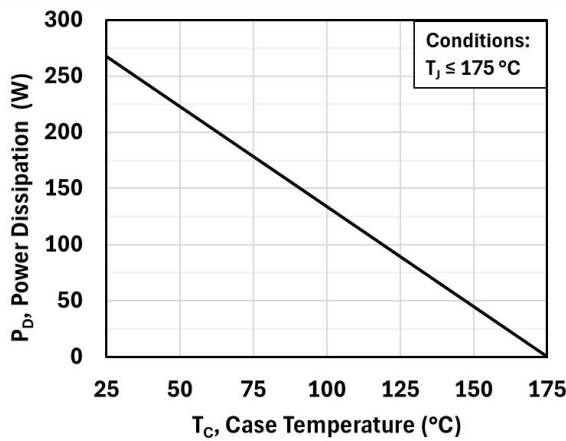

Figure 14: Power De-rating Curve

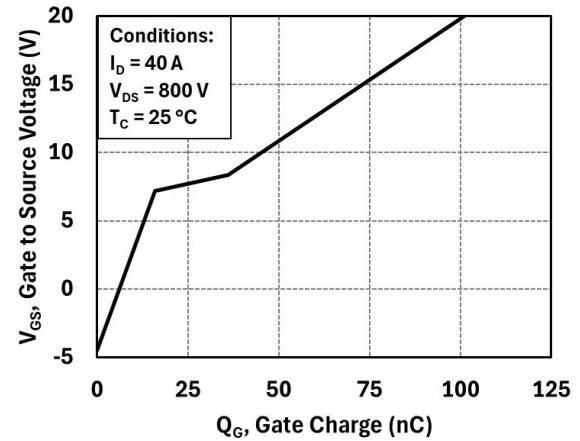

Figure 15: Gate Charge Characteristics

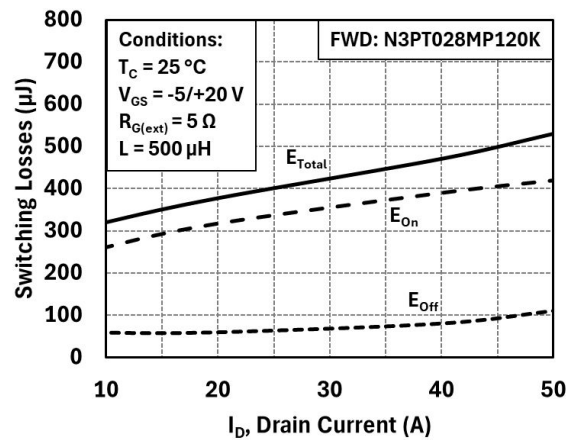

Figure 16: Inductive Switching Energy vs. Drain Current ($V_{DD} = 800$ V)

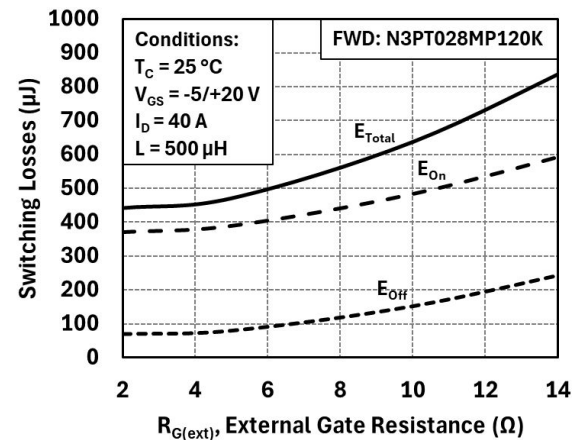

Figure 17: Inductive Switching Energy vs. $R_{G(ext)}$ ($V_{DD} = 800$ V)

Typical Performance

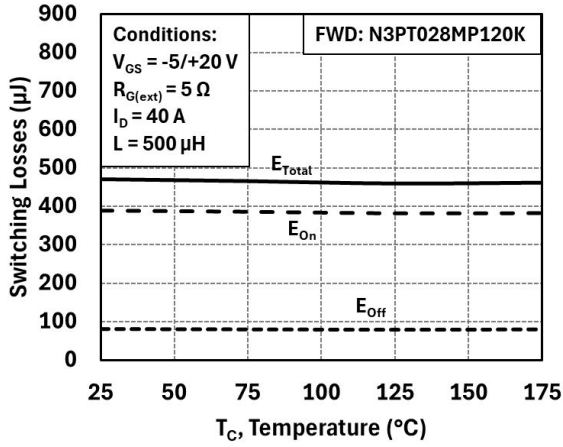

Figure 18: Inductive Switching Energy vs. Temperature (V_{DD} = 800 V)

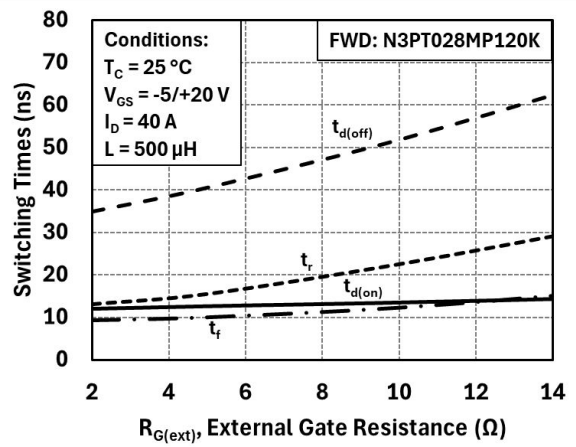

Figure 19: Switching Times vs. R_{G(ext)} (V_{DD} = 800 V)

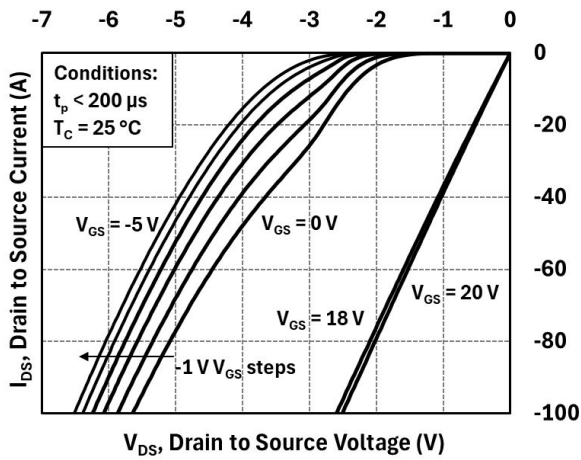

Figure 20: Body Diode Characteristics at 25 °C

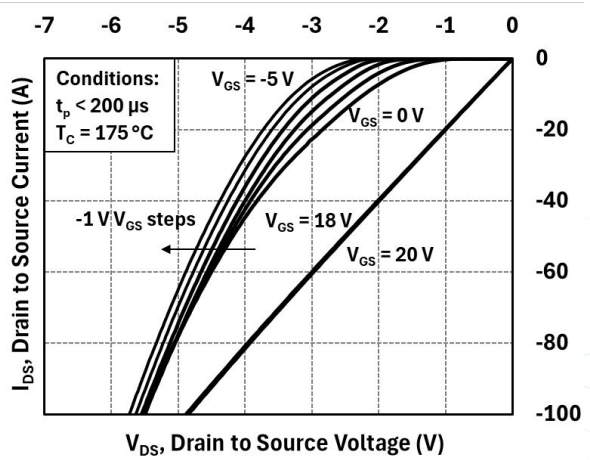

Figure 21: Body Diode Characteristics at 175 °C

Dynamic Testing Circuit Schematics

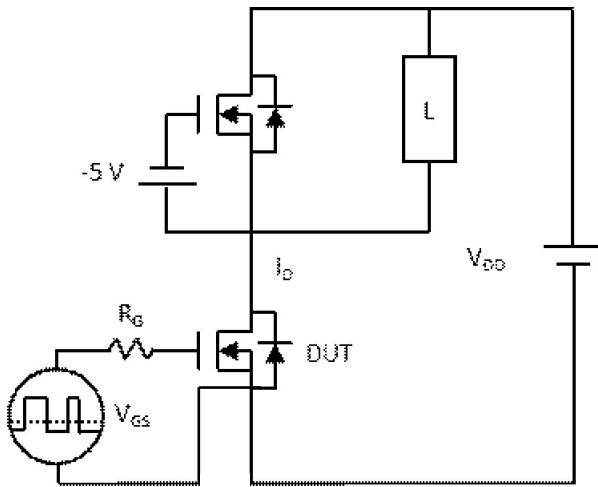

Figure 22: Inductive Load Switching Test Circuit

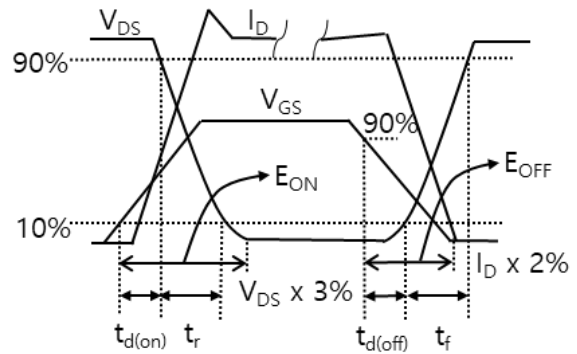

Figure 23: Inductive Load Switching Test Waveforms

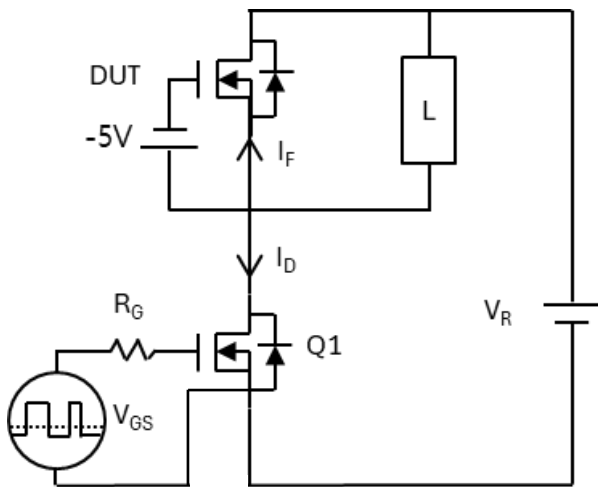

Figure 24: Reverse Recovery Test Circuit

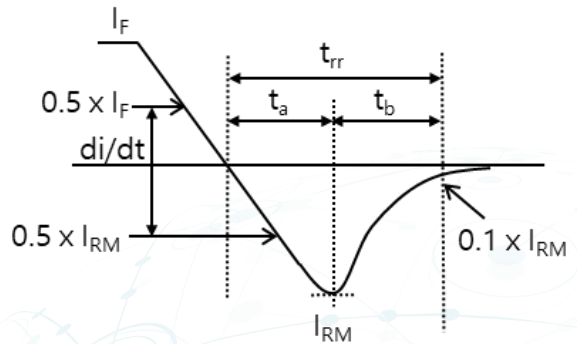

Figure 25: Body Diode Reverse Recovery Test Waveforms

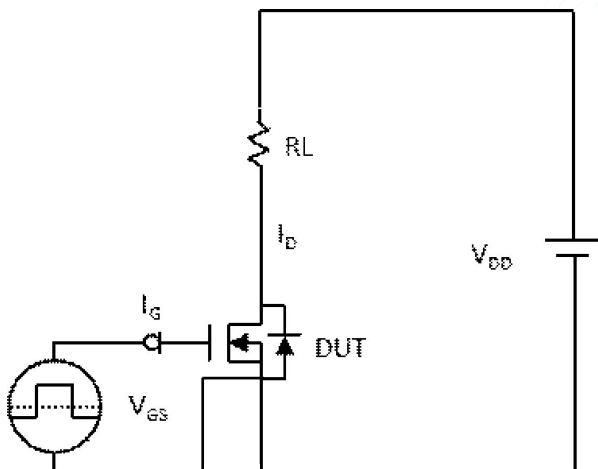

Figure 26: Gate Charge Test Circuit

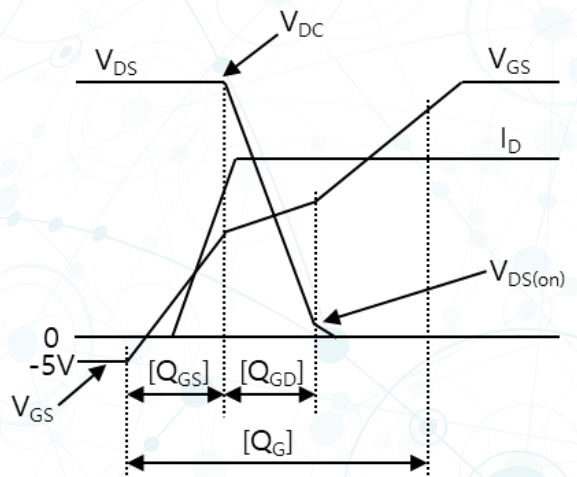
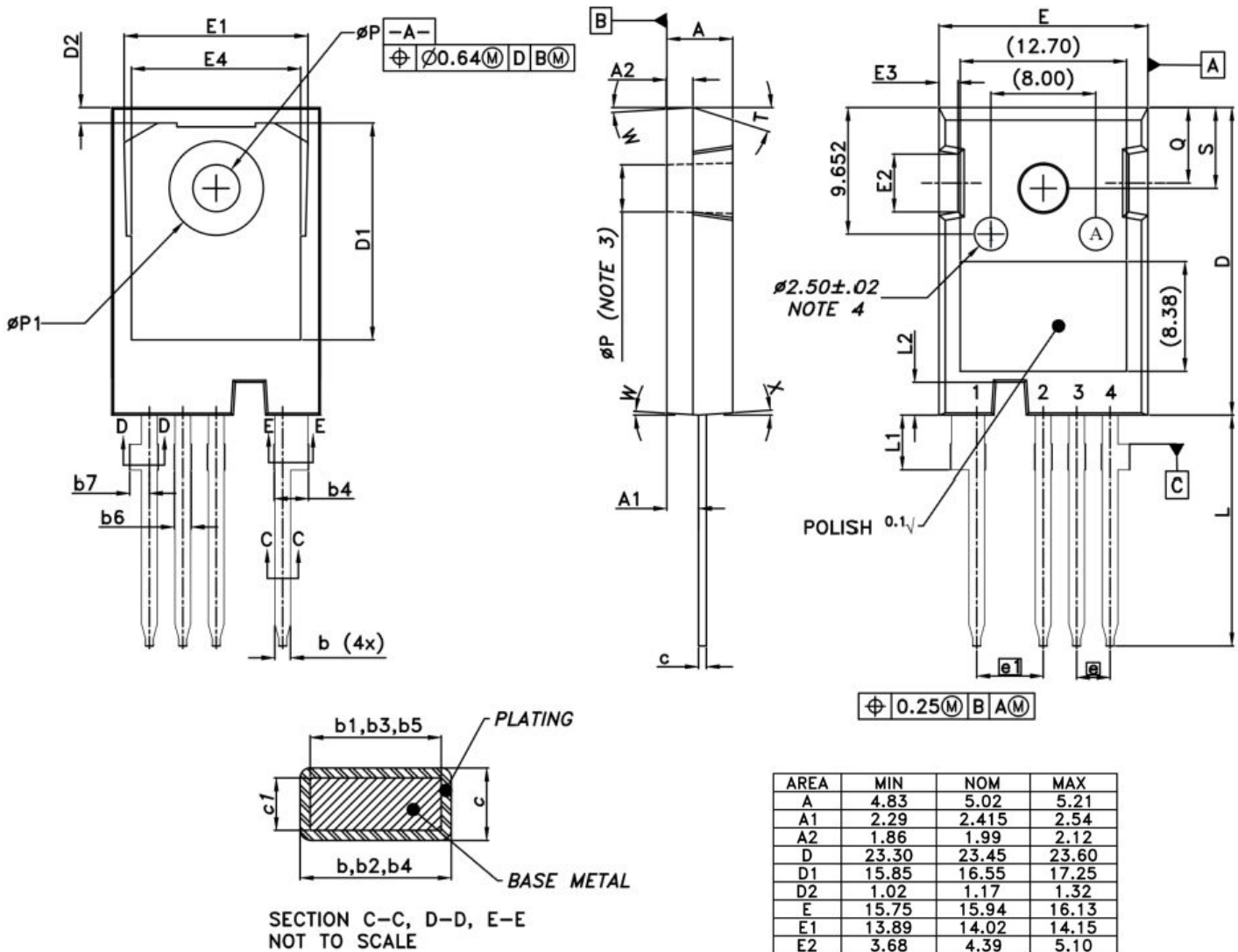

Figure 27: Gate Charge Test Waveforms

Package Dimensions



NOTES:

1. DIMENSIONS ARE IN MILLIMETERS
2. DIMENSION D & E DO NOT INCLUDE MOLD FLASH. MOLD FLASH SHALL NOT EXCEED 0.127 MM PER SIDE. THESE DIMENSIONS ARE MEASURED AT THE OUTERMOST EXTREME OF THE PLASTIC BODY.
3. ϕP TO HAVE A MAXIMUM DRAFT ANGLE OF 1.5° TO THE TOP OF THE PART WITH A MAXIMUM HOLE DIAMETER OF 3.65mm.
4. EJECTION MARK DEPTH $0.10^{+0.15}_{-0.08}$

AREA	MIN	NOM	MAX
A	4.83	5.02	5.21
A1	2.29	2.415	2.54
A2	1.86	1.99	2.12
D	23.30	23.45	23.60
D1	15.85	16.55	17.25
D2	1.02	1.17	1.32
E	15.75	15.94	16.13
E1	13.89	14.02	14.15
E2	3.68	4.39	5.10
E3	1.00	1.45	1.90
E4	12.38	12.91	13.43
e	2.540 BSC		
e1	5.080 BSC		
L	17.31	17.57	17.82
L1	3.97	4.17	4.37
L2	2.35	2.50	2.65
b	1.07	-	1.33
b1	1.07	1.20	1.28
b2	2.39	-	2.64
b3	2.39	-	2.69
b4	2.39	-	2.94
b5	2.39	2.53	2.84
b6	1.07	-	1.60
b7	1.30	-	1.70
c	0.55	-	0.68
c1	0.55	0.60	0.65
ϕP	3.51	3.58	3.65
Q	5.49	5.75	6.00
S	6.04	6.15	6.30
$\phi P1$	7.18 REF		
T	17.5° REF		
W	3.5° REF		
X	4° REF		

Warranty & Disclaimers

Since NoMIS Power does not control the use of its products, there are no express warranties that extend beyond the description herein.

THIS PRODUCT IS PROVIDED "AS IS". NOMIS POWER MAKES NO REPRESENTATIONS OR WARRANTIES OF ANY KIND WHETHER EXPRESS OR IMPLIED, WRITTEN OR ORAL, STATUTORY OR OTHERWISE, RELATED TO THE PRODUCT INCLUDING BUT NOT LIMITED TO ANY IMPLIED WARRANTIES OF NON-INFRINGEMENT, MERCHANTABILITY, AND FITNESS FOR A PARTICULAR PURPOSE, OR WARRANTIES RELATED TO ITS CONDITION, QUALITY, OR PERFORMANCE. IN NO EVENT WILL NOMIS POWER BE LIABLE FOR ANY INDIRECT, SPECIAL, PUNITIVE, INCIDENTAL, OR CONSEQUENTIAL LOSS, DAMAGE, COST, OR EXPENSE OF ANY KIND WHATSOEVER (INCLUDING, WITHOUT LIMITATION, DAMAGES FOR LOSS OF PROFIT, BUSINESS INTERRUPTION, OR LOSS OF INFORMATION) RELATED TO THE USE OF, OR INABILITY TO USE, THE PRODUCT, HOWEVER CAUSED, EVEN IF NOMIS POWER HAS BEEN ADVISED OF THE POSSIBILITY OF SUCH DAMAGES OR THE DAMAGES ARE FORESEEABLE. TO THE FULLEST EXTENT ALLOWED BY LAW, NOMIS POWER'S TOTAL LIABILITY ON ALL CLAIMS IN ANY WAY RELATED TO THE PRODUCT OR ITS USE, OR INABILITY TO USE, WILL NOT EXCEED THE AMOUNT OF FEES, IF ANY, THAT YOU HAVE PAID DIRECTLY TO THE SELLER FOR THE PRODUCT.

NoMIS Power's products are not recommended or authorized for usage in equipment or applications that require extraordinarily high quality and/or reliability or a malfunction or failure of which may cause loss of human life or bodily injury, such as life support or medical instruments or applications. Buyers assume all risk and liability for using our products in such applications and agree to defend, indemnify and hold harmless NoMIS Power from any and all damages, claims, suits or expenses resulting from such use.

NoMIS Power further does not warrant the accuracy or completeness of the information, text, graphics, links or other items contained in this Data Sheet. This Data Sheet and the information herein may be used only with NoMIS Power products, including to design, test, and integrate NoMIS Power products with your application. Use of this information in any other manner violates these terms. Information regarding device application is provided only for your convenience and may be superseded by updates at any time. It is your responsibility to ensure that your application meets with your specifications. NoMIS Power may make changes to this Data Sheet at any time, or to the product described herein, at any time without notice.

No licenses are conveyed, implicitly or otherwise, under any NoMIS Power intellectual property rights.

NoMIS Power and  **NoMIS P_c** are trademarks of NoMIS Power Corporation in the United States and/or other countries. NoMIS Power reserves the right to make changes without further notice to any products herein. NoMIS Power makes no warranty, representation or guarantee regarding the suitability of its products for any particular purpose, nor does NoMIS Power assume any liability arising out of the application or use of any product or circuit, and specifically disclaims any and all liability, including without limitation special, consequential or incidental damages. NoMIS Power does not convey any license under its patent rights nor the rights of others.

NoMIS Power Corporation
251 Fuller Rd, Albany, NY 12203, USA
together@NoMISPower.com | NoMISPower.com